

William PL72 - 120

Technical Documentation

COD. 5200072TC

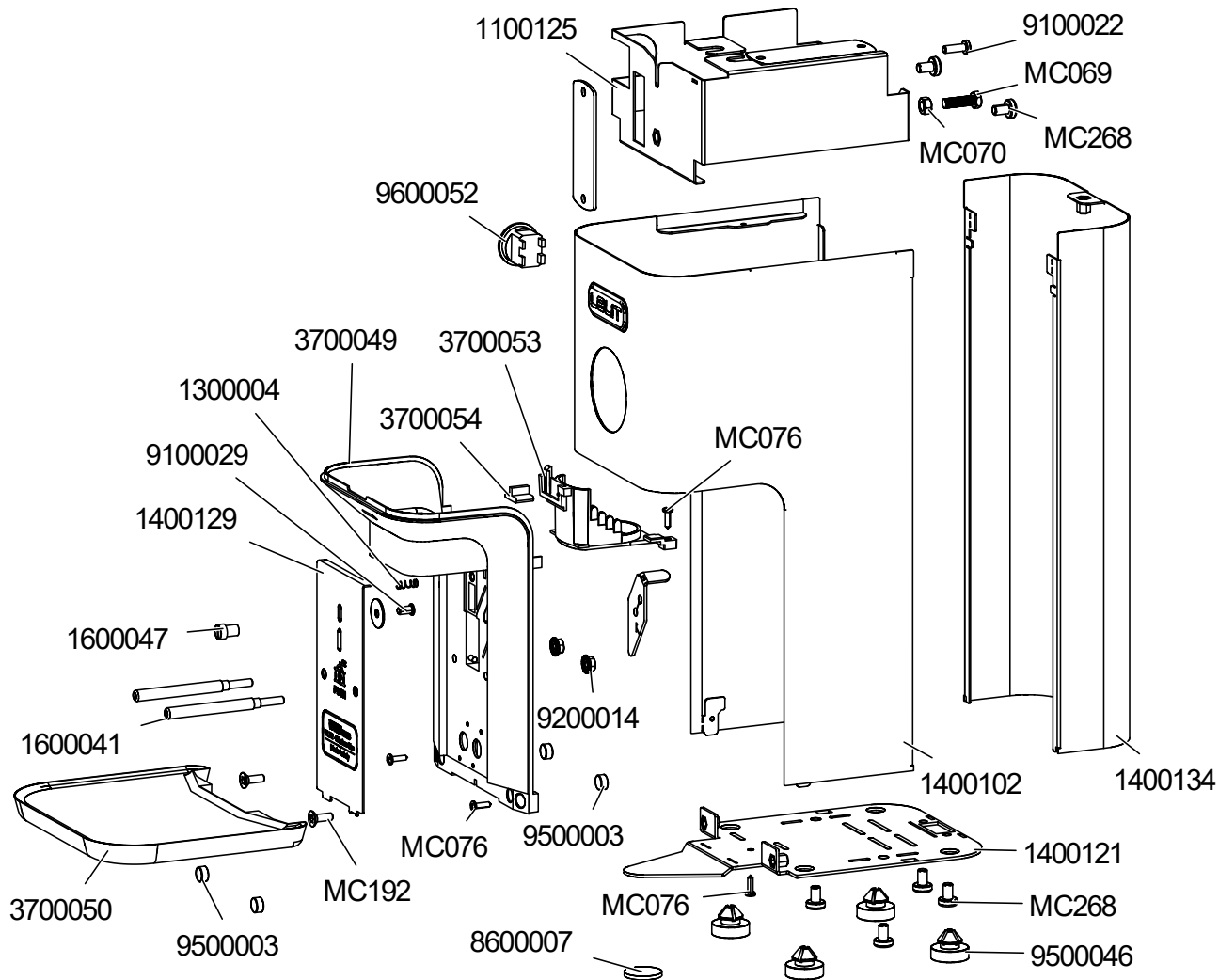

CODE	DESCRIPTION
1100025	LLC SUPPORT FOR PL72
1300004	SPRING D.4 H 12
1400102	FRONT APPLIANCE BODY PL72
1400121	BASE PL71
1400129	PLATE FOR GRINDING SWITCH PL72
1400134	BACK PANEL PL72
1600041	PIN D. 6 L=50 PL71
1600047	PORTAFILTER PINS FOR WILLIAM GRINDERS
3700049	FRONT PANEL PL71
3700050	COFFEE REST TRAY PL71
3700053	REGULATING DEVICE FOR COFFEE CHUTE PL71
3700054	LED PL71
8600007	ADHESIVE RUBBER Diam.20 H2
9100022	SCREW 4Mx6 FOR FIXING THE THERMOSTAT
9100029	LOCKER M4X8
9200014	NUT M4 DIN6923 ZB INOX
9500003	MAGNET Diam.8 x h4
9500046	DYN FOOT
9600052	ROUND MAIN SWITCH
MC069	SCREW M5X20 ZNB
MC070	NUT M5
MC076	SCREW TCBIC 2,9x9,5 UNI ISO 7049
MC192	SCREW M4x12 DIN965 TORX T20
MC268	SCREW M5x8

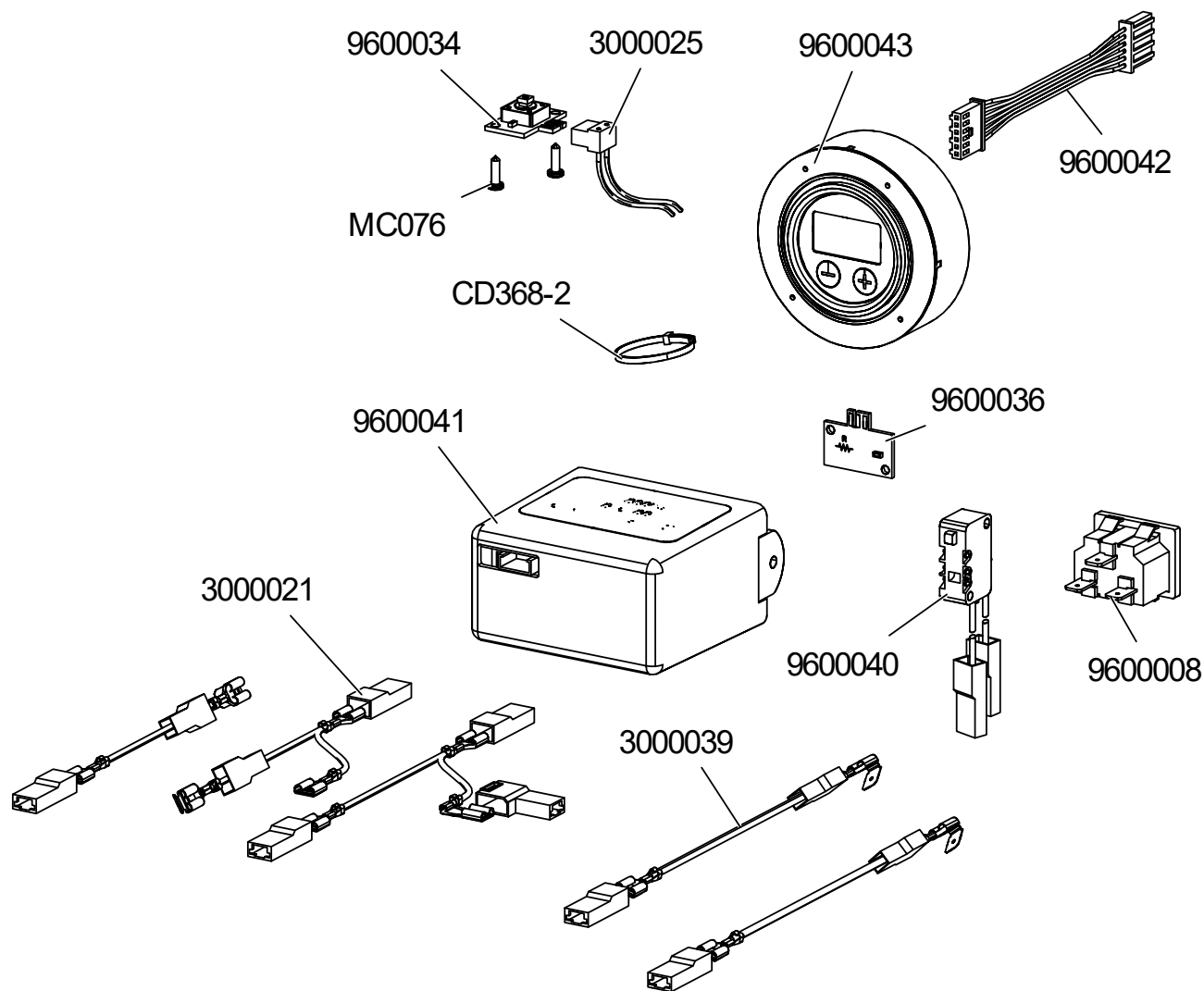

CODE	DESCRIPTION
3000021	WIRING
3000025	WIRING FOR CONTINUOUS SWITCH + LED PL72
3000039	ADDITIONAL WIRING FOR CAPACITOR ON PL72-120
9600008	IEC PANEL SOCKET 10A250V 2P+T. F.F.6.3X0.8
9600034	SWITCH WITH DOUBLE LED
9600036	MONO LED
9600040	MICRO WITH WIRES L=26 FEMALE FASTON
9600041	ELECTRONIC CARD PL72
9600042	FLAT CABLE DISPLAY LCC
9600043	KIT GRAPHIC DISPLAY PL72
CD368/2	WHITE CLAMP FOR SPRING
MC076	SCREW TCBIC 2,9x9,5 UNI ISO 7049

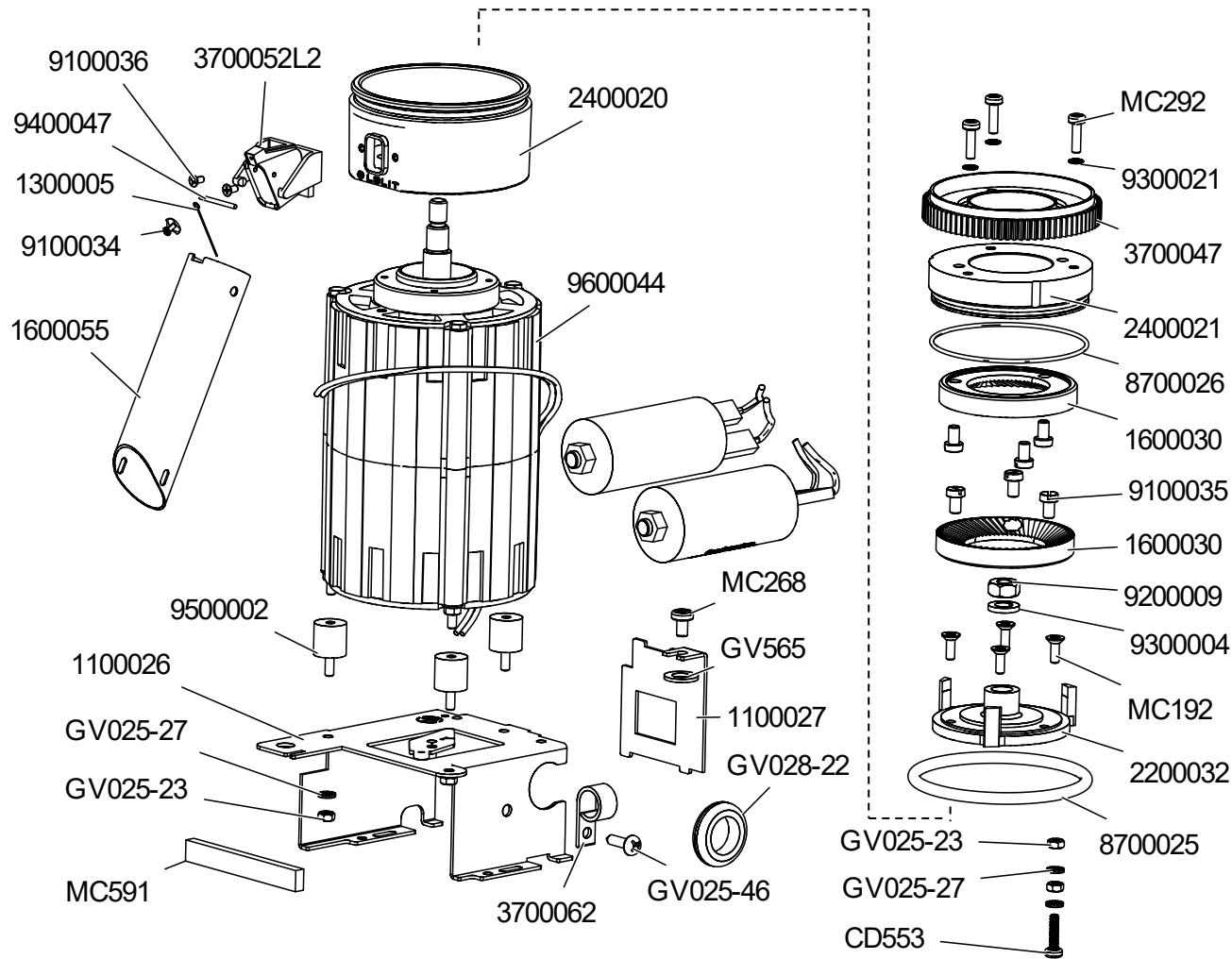

CODE	DESCRIPTION
1100026	MOTOR SUPPORT PL71
1100027	ELECTRONIC CARD SUPPORT PL71
1300005	SPRING FOR COFFEE DIVISION
1600030	FLAT BURR MILL Diam.64
1600055	COFFEE CHUTE
2200032	LOWER MILLS SUPPORT FOR PL72
2400020	CILINDER PL72
2400021	UPPER MILLS RING PL72
3700047	GRINDING FERRULE UPPER MILLS PL72
3700052L2	CHUTE SUPPORT PL71
3700062	CABLE RETAINER WITH SCREW Diam.12,7
8700025	OR GASKET 179
8700026	GASKET 2274 Diam.i69, 57 t1,78 NBR 70sh ±5
9100034	SELF-TAPPING SCREW TCBIC
9100035	SCREW TCCI M5X8 UNI 6107 (A2)
9100036	SCREW TSPIC M3x6 UNI7046 4.8 (zb)
9200009	NUT M8 UNI EN ISO 4032 A2
9300004	WASHER GROWER M8 UNI 1751 ZNB
9300021	SCHNORR ELASTIC WASHER
9400047	CYLINDRICAL PLUG
9500002	CILINDRIC ANTIVIBRATION
9600044	MONOPHASE MOTOR 115V 50/60Hz
CD553	SCREW TCBIC M4x16 UNI 7687 (4.8 ZB)
GV025/23	NUT 4MA 5588 ZNB
GV025/27	WASHER D4 UNI8842
GV025/46	SCREW 4,8x16
GV028/22	FAIRLEAD FOR TAP FOR 028 029
GV565	FLAT WASHER
MC192	SCREW M4x12 DIN965 TORX T20
MC268	SCREW M5x8
MC292	SCREW 4MA FOR COFFEE GRINDER
MC591	ADHESIVE SPONGE

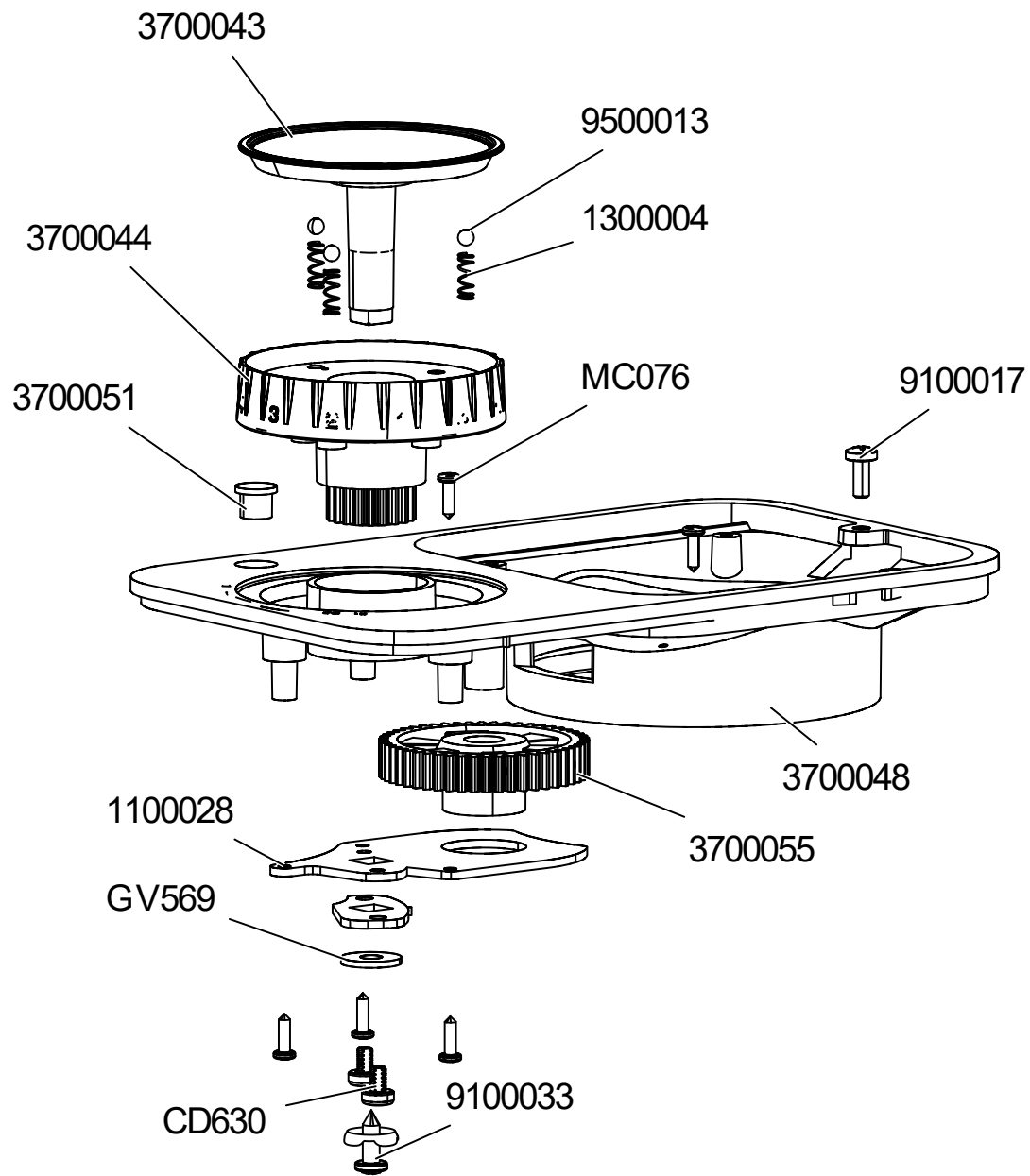

CODE	DESCRIPTION
1100028	MEDIUM MILL SUPPORT PL71
1300004	SPRING D.4 H 12
3700043	COVER FOR GRINDING KNOB PL71
3700044	GRINDING KNOB PL71
3700048	COVER PL71
3700051	SWITCH PL71
3700055	MEDIUM GEAR PL71
9100017	SCREW M4x10 UNI7687 4.8
9100033	SELF-TAPPING SCREW
9500013	INOX SPHERE Diam.4
CD630	SCREW M4x6
GV569	WASHER FOR WHEELS
MC076	SCREW TCBIC 2,9x9,5 UNI ISO 7049

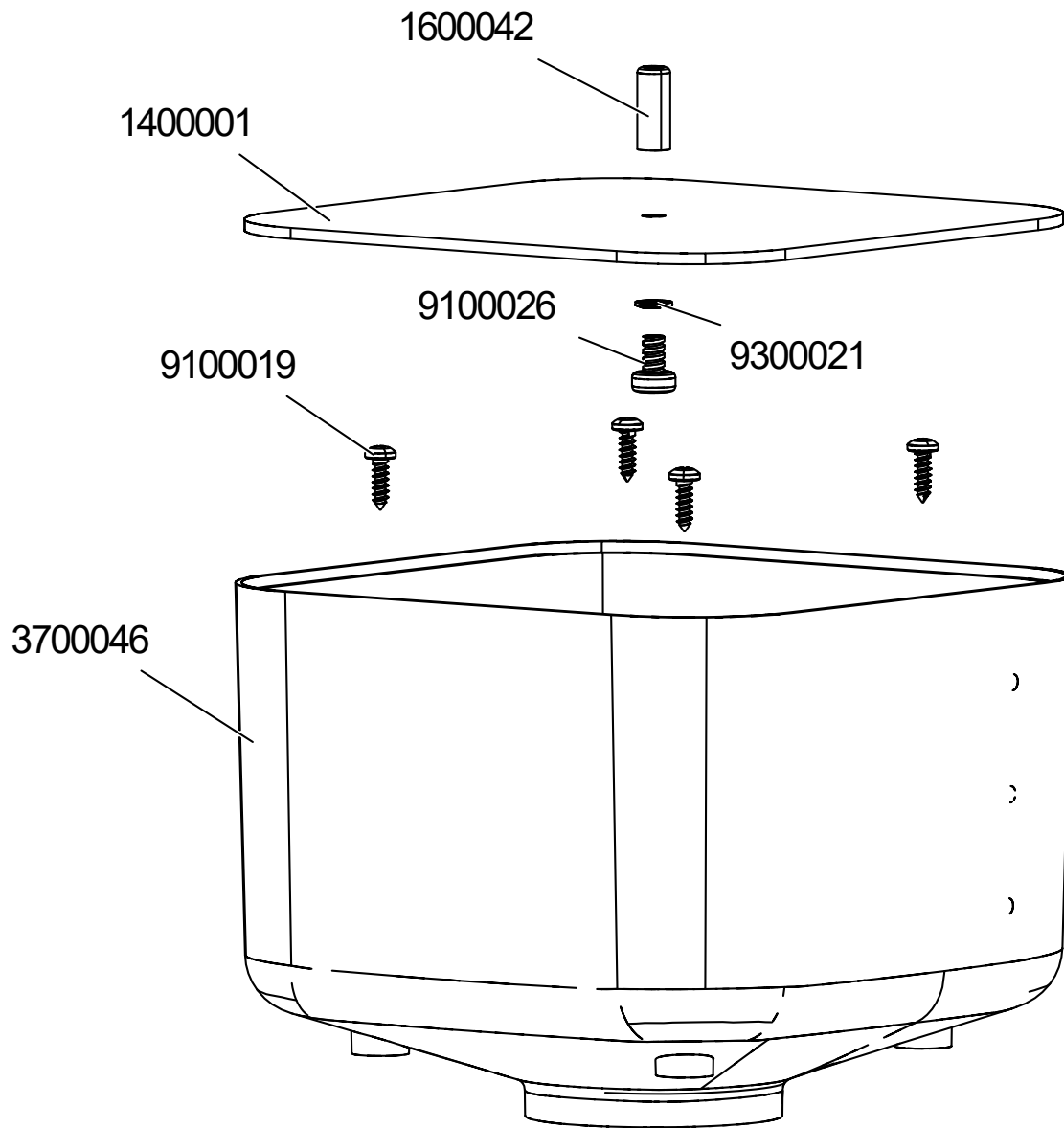

CODE	DESCRIPTION
1400001	HOPPER LID
1600042	PIN D=6 L=15 PL71
3700046	BEAN HOPPER 350g
9100019	STAINLESS STEEL SCREW TCBIC 2,9x9,5 UNI ISO 7049
9100026	SCREW TCBIC M4x10 UNI 7687 INOX
9300021	SCHNORR ELASTIC WASHER

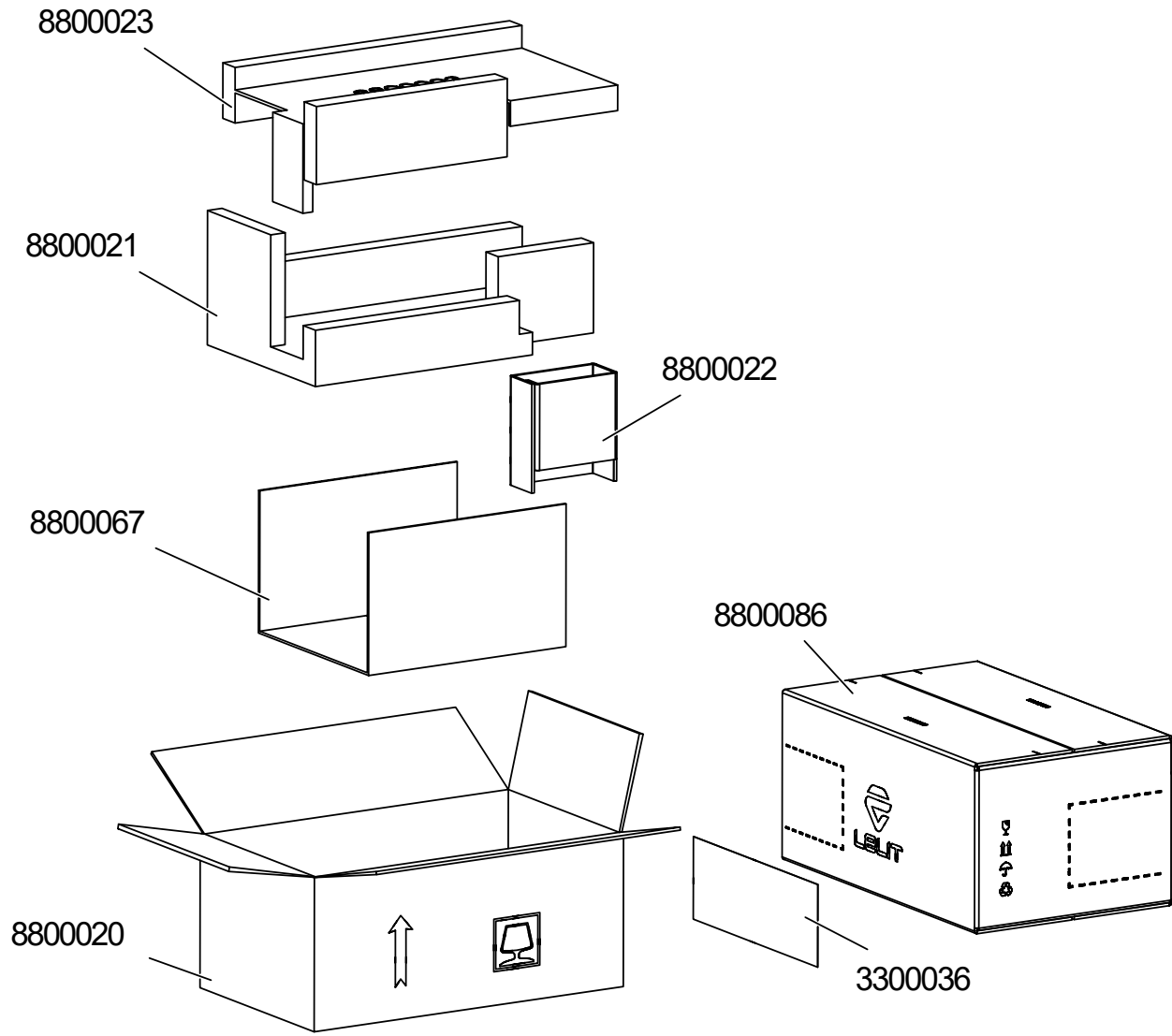

CODE	DESCRIPTION
3300036	LABEL
8800020	EXTERNAL CARTON BOX
8800021	LOWER CARTON PART
8800022	INTERNAL CARTON SPACER
8800023	UPPER CARTON PART
8600067	CARTON SUPPORT
8600086	MASTER CARTON

MC269 (EUROPE)

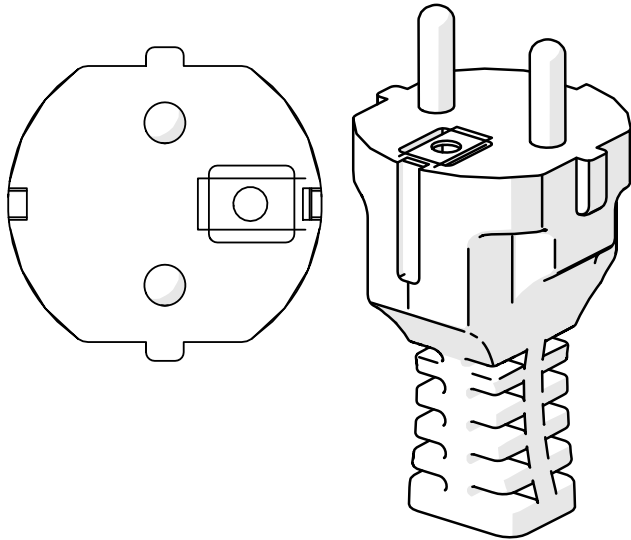

MC269-110 (UNITED STATES)

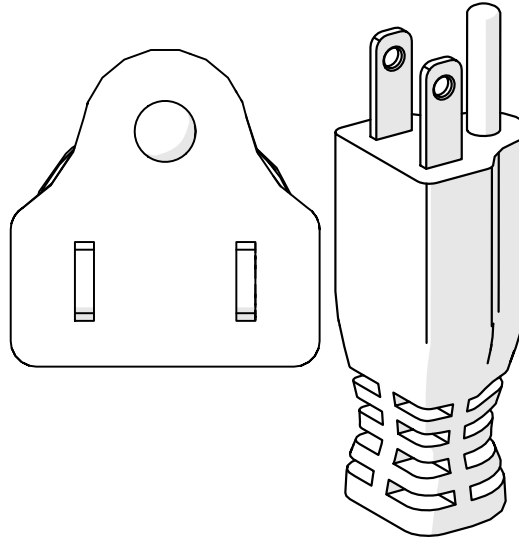

MC269UK (UNITED KINGDOM)

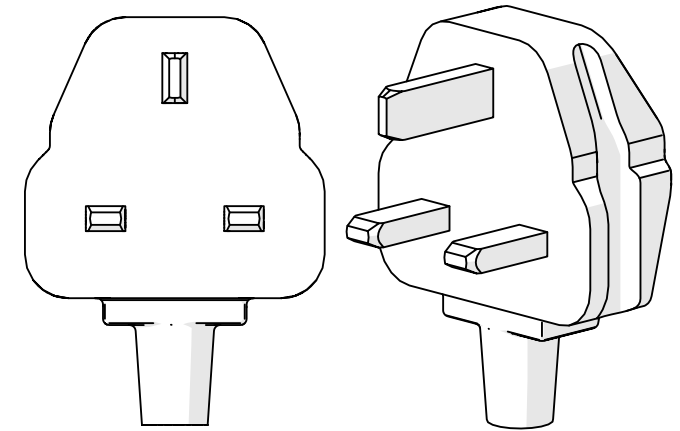

MC269IL (ISRAEL)

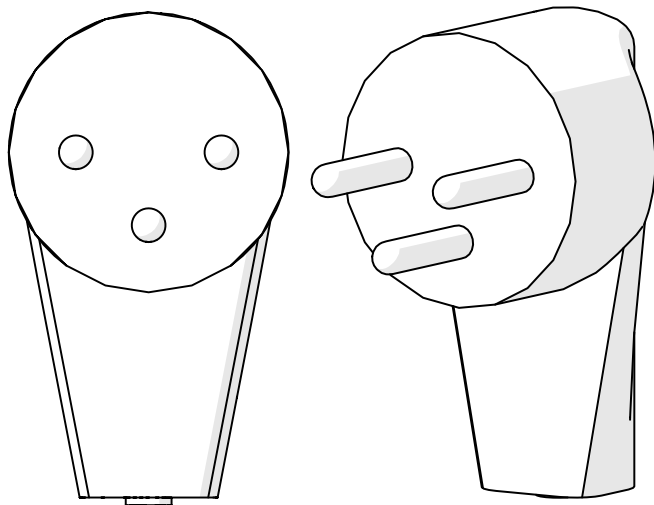

MC269AUS (AUSTRALIA)

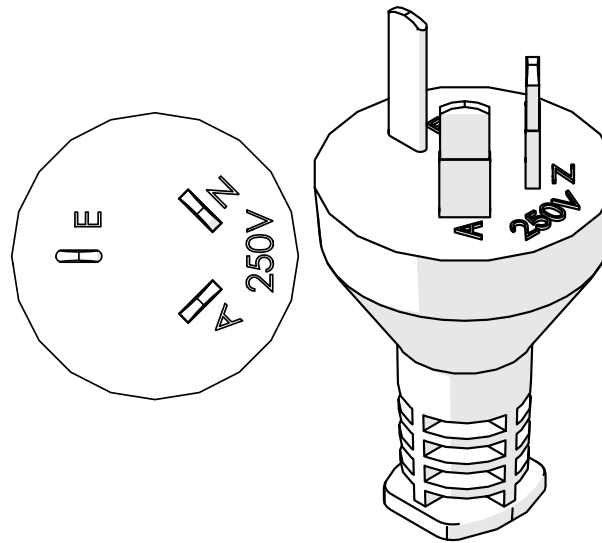

MC269-100 (JAPAN)

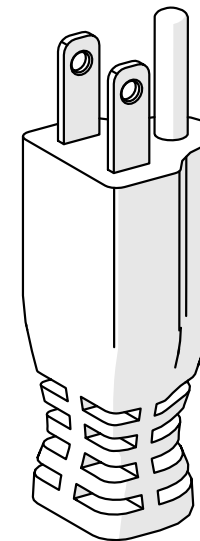

MC269CHN (CHINA)

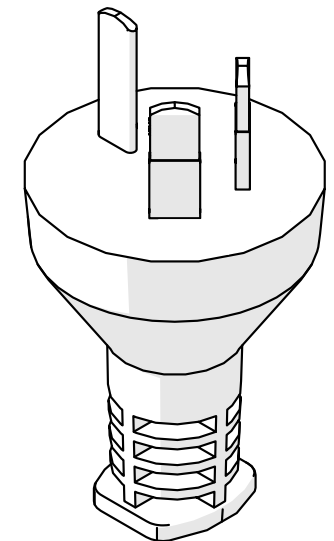

PLA9202

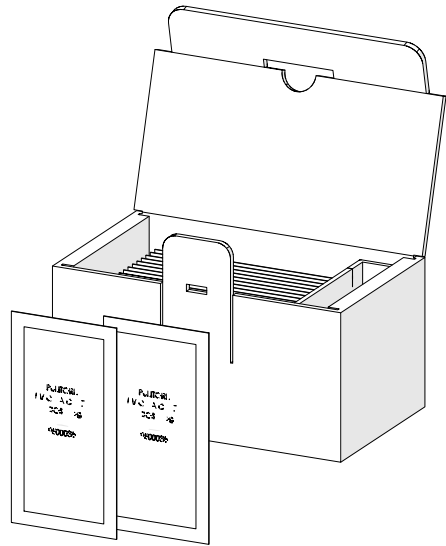

CODE

DESCRIPTION

PLA9202

BURRS CLEANING KIT