

MODIFICATIONS: MODIFIED MARKED WITH:

7	8	9
10	11	12

MODIFICATIONS: MODIFIED MARKED WITH:

1	2	3
4	5	6

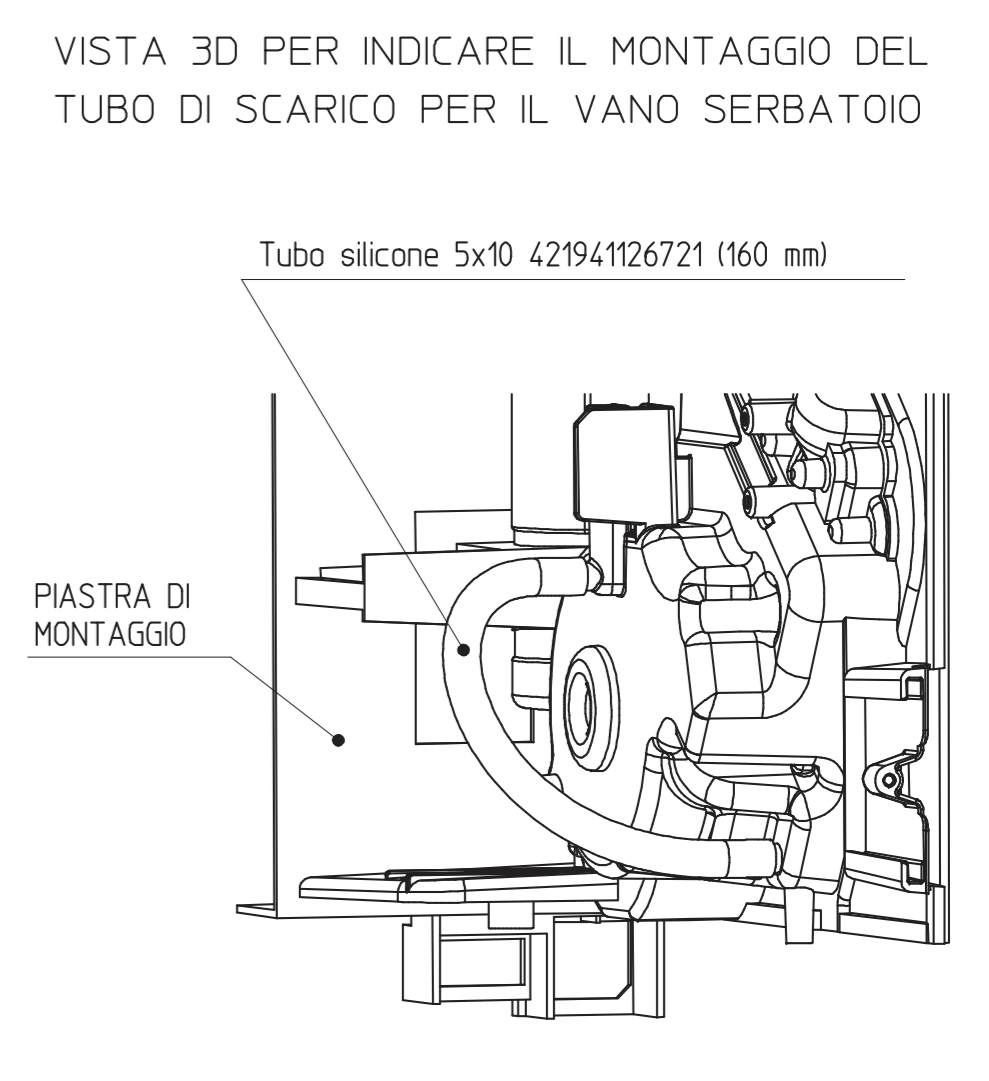
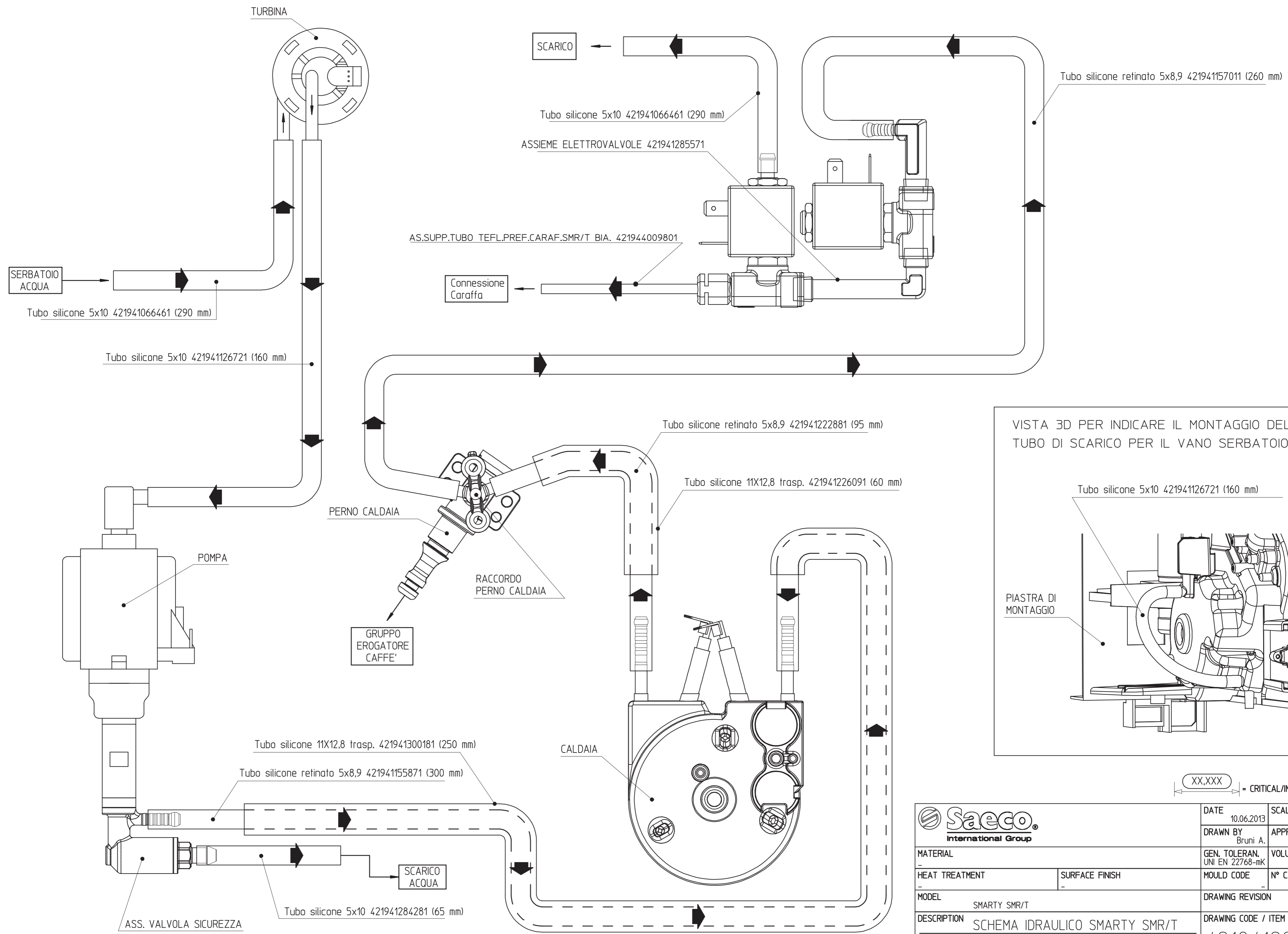
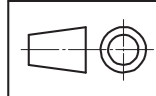

XX,XXX = CRITICAL/IMPORTANT

	DATE	10.06.2013	SCALE	NO SCALE
	DRAWN BY	Bruni A.	APPROVED	Tonelli S.
MATERIAL	GEN. TOLERAN.	UNI EN 22768-mK	VOLUME (mm ³)	-
HEAT TREATMENT	SURFACE FINISH	MOULD CODE	N° CAVITY	-
MODEL	SMARTY SMR/T	DRAWING REVISION	00	
DESCRIPTION	SCHEMA IDRAULICO SMARTY SMR/T		DRAWING CODE / ITEM CODE	
	HYDRAULIC LAYOUT SMARTY SMR/T		421941291301	