

VALIDO PER  
PRODUZIONE

MATERIAL REV. 00

MODIFICATIONS: MODIFIED MARKED WITH:  
⑩ ⑪ ⑫  
⑦ ⑧ ⑨

MODIFICATIONS: MODIFIED MARKED WITH:  
① ② ③

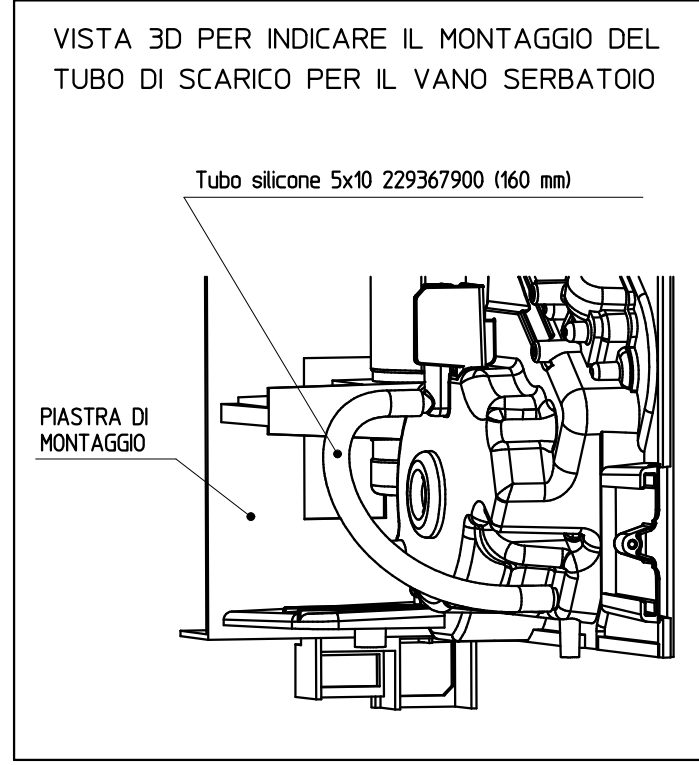
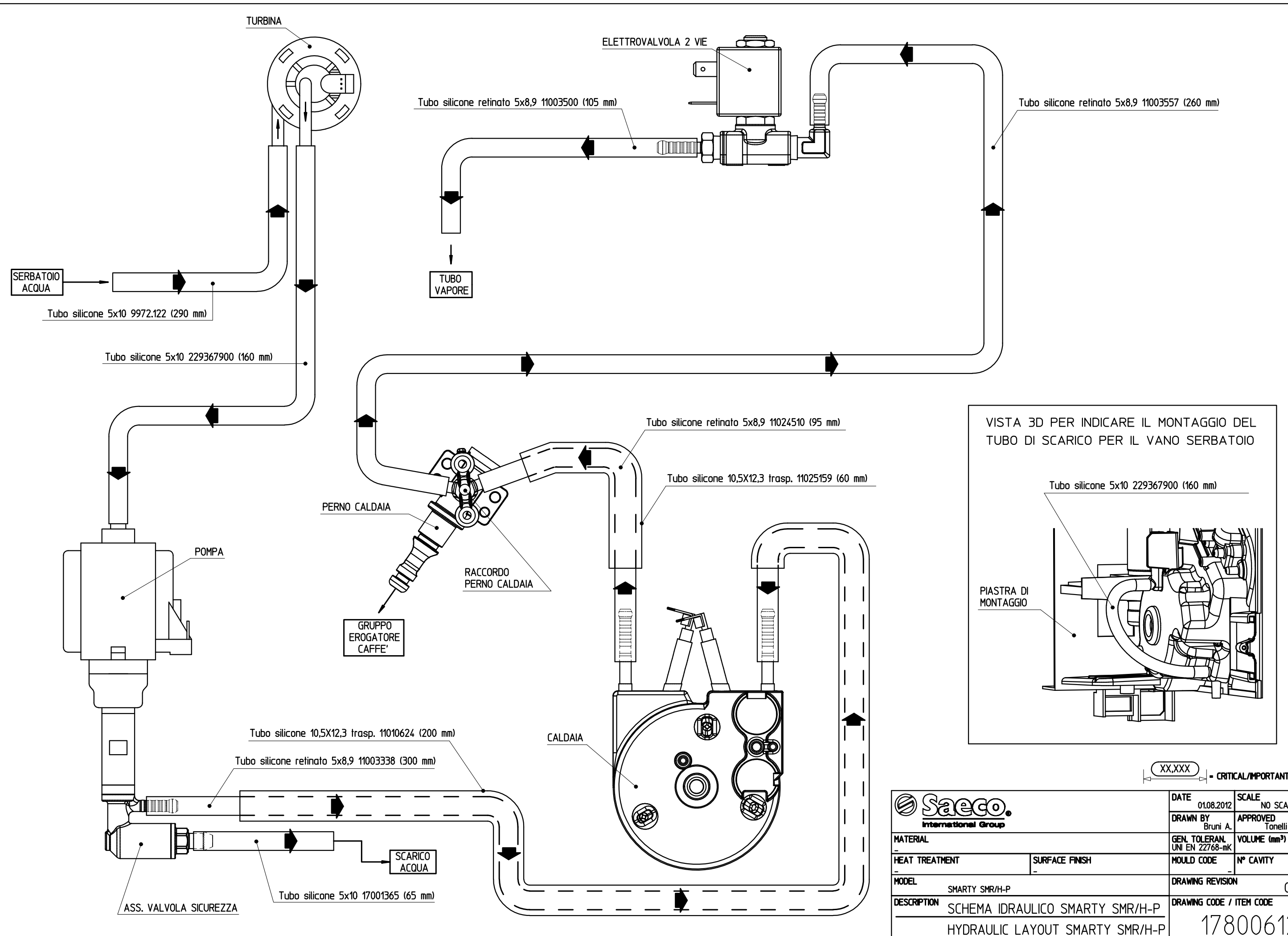
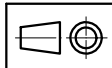

XX,XXX - CRITICAL/IMPORTANT

	DATE	01.08.2012	SCALE	NO SCALE
	DRAWN BY	Bruni A.	APPROVED	Tonelli S.
MATERIAL	GEN. TOLERAN.	UNI EN 22768-mK	VOLUME (mm <sup>3</sup> )	-
HEAT TREATMENT	SURFACE FINISH	MOULD CODE	N° CAVITY	-
MODEL	SMARTY SMR/H-P	DRAWING REVISION	00	
DESCRIPTION	SCHEMA IDRAULICO SMARTY SMR/H-P		DRAWING CODE / ITEM CODE	
	HYDRAULIC LAYOUT SMARTY SMR/H-P		17800612	